

INSTALLATION INSTRUCTIONS

VEHICLE	HITCH NO.
DODGE DURANGO	75081 87522 44733

EQUIPMENT REQUIRED:

WIRING ACCESS LOCATION: SUV1, SUV2

DRILL BITS:

HITCH REQUIRES 5/8" PIN AND CLIP IF STABILIZING PIN (7651) IS NOT INSTALLED.

WRENCHES: (TIGHTEN ALL FASTENERS WITH TORQUE WRENCH) 3/4, 7/8

DO NOT EXCEED LOWER OF TOWING VEHICLE MFR'S RATINGS OR

HITCH TYPE ▼	MAX GROSS TRLR WT(LB)	MAX TONGUE WT(LB)
WEIGHT DISTRIBUTING	7500	750
WEIGHT CARRYING BALL MOUNT	5000	500
	Accessory rating	D

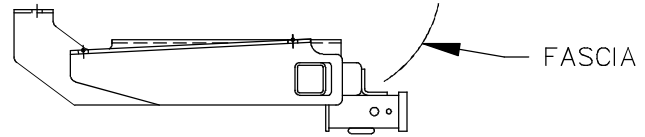

HITCH SHOWN IN PROPER POSITION

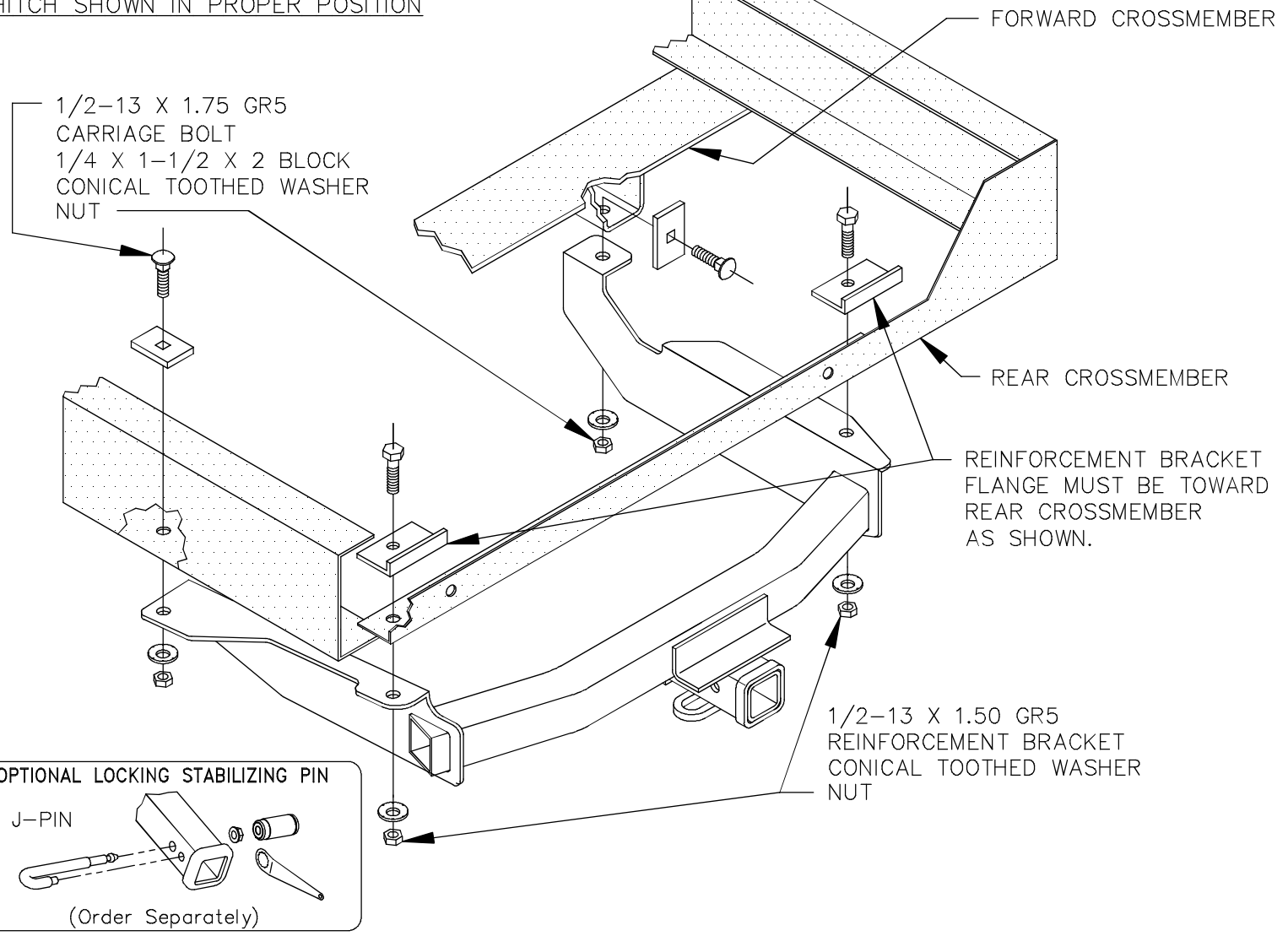

1. RAISE HITCH INTO POSITION AND INSTALL FASTENERS AS SHOWN ABOVE.
NOTE: SOME SPARE TIRES MAY NEED TO BE SLIGHTLY LOOSENED DURING HITCH INSTALLATION. RE-TIGHTEN SPARE TIRE AFTER HITCH HAS BEEN INSTALLED.

TIGHTEN ALL 1/2 GR5 FASTENERS TO 75 LB.-FT.

THIS PRODUCT COMPLIES WITH SAFETY SPECIFICATIONS AND REQUIREMENTS FOR CONNECTING DEVICES AND TOWING SYSTEMS OF THE STATE OF NEW YORK AND V.E.S.C. REGULATION V-5.

APPROX WEIGHT (LB.)	46	FASTENER KIT NO.	F75081
---------------------	----	------------------	--------

NOTE: Check hitch frequently, making sure all fasteners and ball are properly tightened. If hitch is removed, plug all holes in trunk pan or other body panels to prevent entry of water and exhaust fumes. A hitch or ball which has been damaged should be removed and replaced. Observe safety precautions when working beneath a vehicle and wear eye protection. Follow car maker's specs for maximum trailer weight and tongue weight. Do not cut access or attachment holes with a torch.



Plymouth, Michigan